

Dimensions of Work Practice Compatibility and Influences on Actual System Use: Examining Physician Use of Online Disability Evaluation System

(Research in Progress)

Bengisu Tulu

Claremont Graduate University
bengisu.tulu@cgu.edu

Thomas A. Horan

Claremont Graduate University
tom.horan@cgu.edu

Richard Burkhard

Claremont Graduate University
richard.burkhard@cgu.edu

ABSTRACT

This research investigated the effects of work practice compatibility (WPC) on user acceptance and continued use of an online disability evaluation system. The objectives were to examine the work practice compatibility and its effects on actual system use, to assess the patterns of use among the users, and to explore the implications for future system developments. An online web-based survey was distributed to a population of medical professionals, and 97 responses were obtained. Results of bivariate analysis suggested that WPC is an important indicator of actual and continual use. Further analysis revealed associations that give clear indications of the influence of WPC, training, and software features on the relationships between direct and sustained use of the system.

Keywords

Technology acceptance, medical informatics, disability evaluation systems, work practice compatibility.

INTRODUCTION

Information systems have been used in medical fields for many decades and several studies have been conducted to examine the acceptance of these systems. Medical professionals who are the users of health information systems have distinct characteristics that differentiate them from other user groups. Being highly time-constrained and dealing with vital information makes them a challenging user group for technology acceptance. This research is designed to analyze the effects of work practice compatibility (WPC), as first introduced by (Moore and Benbasat 1991), on physician acceptance and adoption of new technologies with a special emphasis on actual use after a period of continuous use. Previous research (Chau and Hu 2001; Moore and Benbasat 1991) studied compatibility in a broad sense.

This research breaks WPC into three sub-constructs (task compatibility (TC), work flow compatibility (WFC), professional compatibility (PC)), to extend the understanding of its effects overall. The effects of other important constructs were also analyzed during this study. The Technology Acceptance Model (TAM) was extended with the addition of a number of dimensions to better explain the adoption and acceptance of new systems in different settings. Perceived behavioral control (PBC) was derived from a related model, the Theory of Planned Behavior (TPB), as an important predictor of behavioral intention (BI) and actual use (AU). Many researchers have examined the effects of training (T) on technology acceptance. A number of studies have shown that usability (U) alone is not a strong predictor of the acceptance or future use of a system. However, it may have an important effect on the actual use and continuous use of the system, and is included in our research model. The following section expands on the literature background and introduces the research model. Later, research methodology is discussed followed by the result of data analysis and conclusion.

BACKGROUND AND CONCEPTUAL APPROACH

Usability, the complex of factors that facilitate direct use of information technologies by physicians, has an extensive research precedent, both on a perceived and actual basis. Rogers' Diffusion of Innovations model (Rogers 1995) as extended by Moore and Benbasat (Moore and Benbasat 1991) presents difficulty of use as a key construct of usability, and helps

conceptually capture the critical obstacle faced by time-pressured physicians. Usability of technologies is often represented in terms of the Technology Acceptance Model (Davis et al. 1989), a well-accepted and widely analyzed approach to understanding behavioral intent to adopt and use a technology. The TAM has recently been examined in terms of user habit and perceived ease of use (PEOU), indicating that habit may have a stronger effect on adoption, and thus physicians' habitual behaviors may present an obstacle to use (Gefen 2003). There is significant precedent in use of TAM and its precursor, TPB, to examine acceptance of technologies by physicians (Chismar and Wiley-Patton 2003; Hu et al. 1999; Succì and Walter 1999). Other research suggests that the functionality set of the technology should match the immediate task needs of the user (Dishaw and Strong 1999), and that the functionality set should therefore be closely matched to the tasks facing physicians. While attitudes have long been recognized as precursors to both immediate and continued use (Bhattacharjee and Premkumar 2004), any measure of usability must include a "cognitive accessibility" that is germane to the physician's field of practice (Bevan 1999).

Training of physicians in information technologies has been shown to affect technology adoption. For example, pre-training of system users, as well as actual training interventions in the medical practice context or field environment, are key "user acceptance enablers" in a variety of environments (Venkatesh et al. 2002). Trialability, which directly proceeds from training, is known to favorably affect adoption of technologies (Karahanna et al. 1999) and prior experience with the technology, an indirect form of training, has a similar result. In addition, formal training of physicians has led to increased likelihood to view computers as beneficial (Schuring and Spil 2000). Finally, lack of training and unfamiliarity with computers has long been viewed as an inhibitor to physician adoption of IT (Eger et al. 2001).

A third element that aids the theoretical basis of this study is perceived behavioral control. In a general sense, such control leads to task-specific plans, that in turn lead to active selection of behaviors such as technology use (Venkatesh and Davis 2000). Perceived usefulness (PU) judgments are formed by professionals such as physicians by comparing what the information system can do with what they need to be done (Venkatesh et al. 2003). Perceived behavioral control can be blocked by expectations of rapid change in technology, or fear of obsolescence in technology, as well as high cost or expectations of price changes. Perceptions of user resources, such as technology interfaces, can affect perceived behavioral control either positively or negatively (Mathieson et al. 2001). Finally, a recently synthesized model, The Unified Theory of Acceptance and Use of Technology (UTAUT) presents performance expectancy and effort expectancy as key determinants of intention and use (Venkatesh et al. 2003). All of these elements may be extended to the context of medical practice.

Figure 1 shows the research model utilized to analyze the effects of the key constructs on actual use and continuous use of the system. The research question under investigation was as follows:

Q1: To what extent does Actual Use vary as a function of Work Practice Compatibility, Training, Usability and Perceived Behavioral Control?

METHODOLOGY

This study focused on the utilization of an online disability evaluation reporting system. Physicians use the system for preparing the medical examination reports for disability claims.

The survey instrument contained 70 items grouped under 8 categories which are (1) General Questions, (2) Training, (3) Online Features, (4) Workflow, (5) Compatibility, (6) System in General, (7) Usability, (8) System Improvements. The variables were measured with a variety of check-off, fill-in, Yes/No and scaled-response items. The first category was handled with every response item type, and the training category questions were a mix of check-off, yes/no, and scaled-response items. Questions under categories 3-7 were measured using a 5-point Likert-scale that ranged from strongly agree and strongly disagree or extremely important to not important. The last category had one open-ended question.

Data was collected from a nationwide survey of physicians who are members of a private provider network. The sample consisted of 97 users out of an estimated 300 frequent users of the online system. Data collection was completed using a two-step process. The web-based survey was first announced through the online system to all the physicians who logged in for a three-week period. This generated 48 responses. Next, a follow-up invitation was sent to physicians who already received training for the online system but did not respond to the questionnaire. A total of 233 follow-up invitation letters were sent to these physicians. This second step generated 49 responses, leading to the final sample size of 97.

DATA ANALYSIS

Descriptive Statistics

Initial analysis of the data started with the descriptive statistics in order to understand the general characteristics of the sample and to identify the common actual use characteristics of the online system users. Among the 97 respondents, age value ranged between 29 to 83 with a median of 48, an average of 49, and a standard deviation of 11.5. Maximum years of performing disability evaluations were 40, with an average of 6.7 years. These respondents were located in 10 different states and they represented 13 different medical specialties.

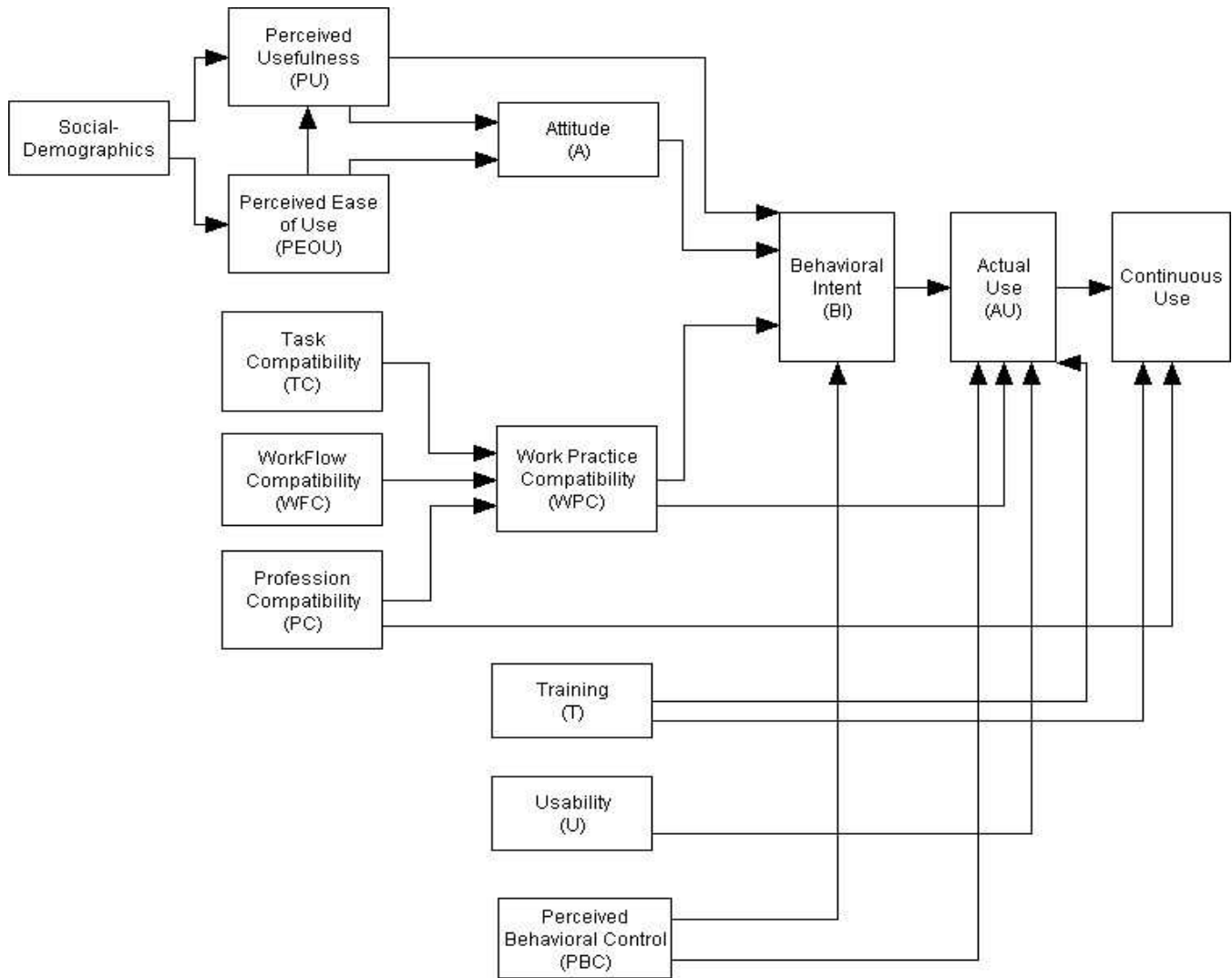

Figure 1 – Research Model

Actual use was studied under three phases: (1) Gathering Data, (2) Entering Data, (3) Finalizing Report. During the data-gathering phase of the medical examination users are expected to use the worksheets provided by the online system. Users are provided two different ways of utilizing these worksheets, printed and online. 55.7% of the respondents reported that they never view online worksheets during the exam, and 58.8% of the respondents reported that they always view printed worksheets during the exam.

Second phase analyzed how the physicians integrate the online system to their work practice. The majority (64.9%) reported that they always enter their own reports directly into the system after the evaluation and 16.5% reported that they always enter their reports directly into the system during the exam. However, 12.4% always prefers to let their assistants enter the data to the system compared to 74.2% that never prefers this method. Location where the data is entered to the system was also analyzed in this study. 53.6% reported that they always prefer to enter data into the system at their office compared to 13.4% never preferred this location. Moreover, 7.2% reported that they always prefer to enter data at home. This implies the use of online system is not limited to the office space and it offers location flexibility to the physicians.

The final phase of the online reporting includes reviewing and finalizing the generated narrative report and providing authentication information that will be stored in electronic format with the final report. Of the respondents, 57.7% reported that they always finalize the reports at the office, 7.2% reported that they always finalize the reports at home, and 11.3% of the participants reported that they always let an assistant to finalize the reports.

Bivariate analysis

Pearson correlations, illustrated in Table 1, were calculated to understand the relationship between independent variables and actual use (AU). In general, the bivariate correlations support the expected relationship between WPC and system use. WPC is positively associated with the actual use of online worksheets during the exam (AU1). Task compatibility (TC), such as the belief that the physician can use the system easily while performing medical evaluations and disagreeing with the statement that the way the system is designed is inconsistent with how they like to conduct exams, is positively correlated with physicians' tendency to use online worksheets during the exam. The belief that the physician can use the system easily while performing medical evaluations is also positively correlated with the physician's practice of entering their own reports directly into the system during the evaluations (AU4). The use of online worksheets during the exam positively correlates with exposure to such systems during conferences or through periodicals.

Table 1 – Correlations between AU items and others¹

	AU 1	AU 2	AU 3	AU 4	AU 5	AU 6	AU 9	AU 10
PU4	.224*							
PU5		.286**						
PU6					.253*			.280**
PU10	.322**							
WPC1	.214*							
WPC2	.276**							
TC1	.443**			.305**				
TC2	.206*							
WFC2					.360**			
PC2					.243*			.237*
PC3	.225*		-.275**		-.220*			
U9					-.254*			
PBC2						-.235*	.201*	
T1					.219*			.357**

An important contribution of this study was introducing new measures for WPC by categorizing it under three constructs, which are expected to have a direct effect on the WPC construct. Table 2 illustrates the relationship between new and old compatibility items. This table shows that under TC and WFC constructs three items and under PC constructs two items produced high correlation with the original WPC items. It indicates at the bivariate level that these items were suitable for measuring different dimensions of the work practice compatibility.

¹ Construct acronyms are followed by item number, e.g., WPC3 refers to the third item of the work practice compatibility construct.

Table 2 – Correlations between WPC items¹

	TC1	TC2	TC3	WFC1	WFC2	WFC3	WFC4	PC1	PC2	PC3	PC4
WPC1	.385**	.516**	.411**	.667**		.583**	.499**		.412**		.537**
WPC2	.371**	.576**	.304**	.611**		.619**	.450**		.482**		.507**
WPC3	.350**	.464**	.339**	.639**		.460**	.498**	.221*	.470**		.496**

RESEARCH DIRECTIONS

Previous research (Mathieson et al. 2001) had introduced perceived user resources as an extension to TAM by introducing a new set of measures that evaluates the overall perception and underlines the specific causes. This research aims to do a similar study for compatibility by utilizing existing WPC items and introducing new ones. The overall pattern of correlations between the factors expected to affect use and actual use are consistently reasonable and support the expected relationships defined in the research model. One important finding suggests that the way systems are integrated into medical practice is an important indicator of continued use. Other findings related to the research model (and to be included in future analysis):

1. Designing systems that are compatible with physicians' work practices increases the actual direct use.
2. Training increases the direct use of the system by physicians.
3. Providing software features that are useful for the physicians increases the actual direct use.

This research has examined and justified the expectation that initial use of the online system is associated with WPC of the system, quality and frequency of training, and usability of the software features. While additional research will analyze the full research model of the study, this paper presents WPC findings relative to actual use. The results also showed that physicians appreciate the online system and usability of software features appears to directly affect actual and continued use. However, once the initial use hurdle has been crossed, physicians are likely to bring their time-pressured and clinically demanding professional approach to the evaluation of the system features and usability, which may result in mixed evaluations. In addition to WPC, the focus of the research team's continued research will be to further examine the relationship between continued use of the online system and WPC and usability, and analysis of the full research model.

ACKNOWLEDGMENTS

This study was conducted as part of a cooperative research agreement between Claremont Graduate University and the QTC Management. The authors gratefully acknowledge the support of QTC Management in terms of providing access to the physician network used in this study, as well as for financial, technical, and administrative support in the conduct of the study. The results reported as well as any inadvertent errors in their reporting are the sole responsibility of the paper authors.

REFERENCES

1. Bevan, N. (1999). "Quality in use for all." User interfaces for all, C. Stephanidis, ed., Lawrence Erlbaum, Mahwah, N.J.
2. Bhattacharjee, A., and Premkumar, G. (2004). "Understanding Changes in Belief and Attitude Toward Information Technology Usage: A Theoretical Model and Longitudinal Test." *MIS Quarterly*, 28(2), 229-254.
3. Chau, P. Y. K., and Hu, P. J.-H. (2001). "Information Technology Acceptance by Individual Professionals: A Model Comparison Approach." *Decision Sciences*, 32(4), 699-719.
4. Chismar, W., and Wiley-Patton, S. "Does the Technology Acceptance Model Apply to Physicians?" *Proceedings of the 36th Hawaii International Conference on System Sciences (HICSS '03)*.
5. Davis, F., Bagozzi, R., and Warshaw, P. (1989). "User Acceptance of Computer Technology: A Comparison of Two Theoretical Models." *Management Science*, 35(8), 982-1003.
6. Dishaw, M., and Strong, D. (1999). "Extending the technology acceptance model with task-technology fit constructs." *Information and Management*, 36, 9-21.
7. Eger, M., Godkin, R., and Valentine, S. (2001). "Physician's Adoption of Information Technology: A Consumer Behavior Approach." *Health Marketing Quarterly*, 19(2), 3-21.
8. Gefen, D. (2003). "TAM or Just Plain Habit: A Look at Experienced Online Shoppers." *Journal of End User Computing*, 15(3), 1-13.

9. Hu, P., Sheng, O., Chau, P., Tam, K., and Fung, H. "Investigating Physician Acceptance of Telemedicine Technology: A Survey Study in Hong Kong." *Proceedings of the 32nd Hawaii International Conference on System Sciences (HICSS '99)*.
10. Karahanna, E., Straub, D., and Chervany, N. (1999). "Information Technology Adoption Across Time: A Cross-Sectional Comparison of Pre-Adoption and Post-Adoption Beliefs." *MIS Quarterly*, 23(2), 183-213.
11. Mathieson, K., Peacock, E., and Chin, W. (2001). "Extending the Technology Acceptance Model: The Influence of Perceived User Resources." *The DATA BASE for Advances in Information Systems*, 32(3), 86-112.
12. Moore, G., and Benbasat, I. (1991). "Development of an Instrument to Measure the Perceptions of Adopting an Information Technology Innovation." *Information Systems Research*, 2(3), 192-222.
13. Rogers, E. (1995). *Diffusion of Innovations*, The Free Press, New York.
14. Schuring, R., and Spil, T. (2000). "Assessing Relevance and Micro-Relevance to the Professionals' Working Process as Determinants of IT-Diffusion and IT-Use in Healthcare." *Issues and Trends of IT Management in Contemporary Organizations*, 717-721.
15. Succi, M., and Walter, Z. "Theory of User Acceptance of Information Technologies: An Examination of Health Care Professionals." *Proceedings of the 32nd Hawaii International Conference on System Sciences (HICSS '99)*.
16. Venkatesh, V., and Davis, F. (2000). "A Theoretical Extension of the Technology Acceptance Model: Four Longitudinal Field Studies." *Management Science*, 46(2), 186-204.
17. Venkatesh, V., Morris, M., Davis, G., and Davis, F. (2003). "User Acceptance of Information Technology: Toward a Unified View." *MIS Quarterly*, 27(3), 425-478.
18. Venkatesh, V., Speier, C., and Morris, M. (2002). "User Acceptance Enablers in Individual Decision Making About Technology: Toward an Integrated Model." *Decision Sciences*, 33(2), 297-316.